

Bamboo slicing machine design to increase skewer production

Erwin Yuli Susanto^{1*}, Mulyadi², A'rasy Fahrudin³, Iswanto⁴

^{1,2,3,4}Department of Mechanical Engineering, Muhammadiyah University of Sidoarjo
Jl. Mojopahit 666 B Sidoarjo, 61215

*Corresponding author: erwin.y.susanto@gmail.com

Abstract

Sate is one of the Indonesian specialties whose demand is increasing, so the need for skewers is also getting higher. For this reason, innovation is needed to be able to meet these needs. Because when using skewers in a traditional/manual production method, the quality of the skewers produced is not good and the production capacity is also low. Meanwhile, the existing skewer making machine still has some drawbacks. So in this study, a bamboo cutting machine was designed to increase the production of skewers with innovations to cover the shortcomings of existing machines. In this study, the skewer making machine was designed to have a slicing section, a shavings section (making skewers), and a sharpening section. The skewers produced have a diameter between 2.5 mm to 3 mm and a length of 210 mm with a production capacity of 3000 skewers per hour.

Keywords: Skewers, design, production, shaving, sharpening.

Introduction

Satay is a typical Indonesian culinary that is very popular in Indonesia and has been known by people in various parts of the world [1, 2]. In fact, Indonesian satay is included in the 50 most delicious foods in the world according to the World's 50 Most Delicious Foods survey and ranks 14th [3]. Satay can be found easily in almost all regions, ranging from chicken satay, goat satay, rabbit satay, and other meats [4, 5]. Satay first appeared in the 19th century. Initially, Indonesian people cooked satay by boiling, but after the arrival of Tamil and Gujarat Muslim traders to Indonesia and introducing grilled kebabs, satay began to be cooked by burning. In addition, it is estimated that the way of cooking satay by being stabbed is also inspired by kebabs [6].

With the increasing demand for satay culinary, the need for skewers or commonly called *sujen* is also increasing. Skewers are a promising commodity to be used as a business opportunity [7]. The process of making skewers begins with cutting bamboo as the main ingredient for making skewers. The felled bamboo is cut

into shorter sizes. Furthermore, the bamboo that has been cut is split into small pieces. Then the shaving process is carried out on the bamboo that has been split earlier with a thickness of diameter between 2.5 mm to 3 mm. After the process of shaving the bamboo into bamboo sticks, the next process is cutting the bamboo sticks with a size of 210 mm. The next process is refining the bamboo sticks and the last process is sharpening the bamboo sticks so that they become skewers [8].

In the process of making skewers that are commonly done, the production process still uses manual tools such as knives or hand saws. So that there are still obstacles, namely the results of cutting the skewers are still a lot of fibers on the surface of the cut, the uniformity of the results is uneven, the ends of the skewers are broken, and the time required for the manufacturing process is too long. For this reason, it is necessary to make bamboo cutting and slicing machines to make skewers sticks with the aim of improving the quality of the skewers and increasing the production capacity of the skewers.

Several studies or designs of skewers making machines have been carried out,

including: Design of a bamboo slicing machine for the manufacture of bird cage bars and skewers conducted by Joko Winarno and Rusdiyantoro [9], then Soegiatmo Rahardjo and Ujang Priama who designed the shaver bamboo machine [10] and Gusri Akhyar Ibrahim et al. about the manufacture and testing of mechanical skewer shaver machines [11].

In this study, the machine that will be made will have a drawstring mechanism so that the stick of the skewer becomes pointed. Thus this machine will have more advantages compared to other skewer making machines.

Methods

In this study, the concept that will be used is to design a bamboo slicing machine to increase the production of skewers. At the design stage, the process of designing all component parts of the skewer making machine system will be carried out. The method used in this research consists of two stages, namely: conceptualizing and designing [12–14]. Each stage contains a guide to finding the best solution for each design aspect so that the design process of a bamboo slicing machine to increase skewer production becomes more structured and traceable.

In the first stage, the desired demands on the skewer making machine are determined. From the existing demands, it is used as the basis for determining the functions and parts of the skewer making machine. The next stage is to design alternatives for each part of the skewer making machine along with its drawings. Then choose one of the alternatives for each of the existing parts and combine them to form several variants of the concept of a skewer making machine. The last stage is to provide an assessment of each concept variant and choose it based on the highest value.

Results and Discussion

Concepting Stage

At this stage it is determined what kind of machine will be made along with its specifications. From the manufacture of this machine is expected to fulfill the desire, namely a machine that is simple in construction, easy and comfortable to operate, neat and economical design. While the machine made is expected to be able to make skewers with a diameter between 2.5 mm to 3 mm and a length of 210 mm and is able to produce 3000 skewers in one hour.

From the expected conditions and specifications on the machine to be made, it can be determined the machine parts and their functions as follows:

1. The frame part, which serves to support the entire machine and is able to withstand the stresses that occur so that the whole tool is stable.
2. The driving part, its function is to drive the transmission element generating to the driving shaft.
3. Slicing section, serves to thin the bamboo into the desired size.
4. Drawstring section, serves to make skewers.
5. The sharpening part, its function is to smooth/sharpen the ends of the bamboo to make it sharp.

Design Stage

After determining the parts of the skewer making machine and their respective functions, at this stage an alternative is designed for each part of the skewer making machine. From each alternative for each section, the advantages and disadvantages of each are described along with the design drawings.

1. Frame parts
 - Alternative 1, L profile frame with welded assembly.
Pros: Easier working process, able to reduce vibration, sturdy, easy to get materials.
Disadvantages: difficult to disassemble, difficult to modify, the

components used are many, the assembly process requires experts.

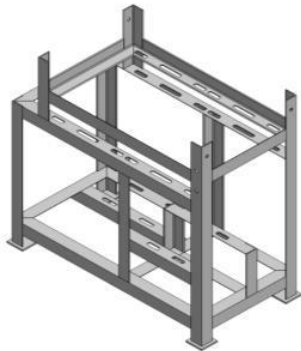

Fig. 1. L profile frame with welded assembly.

- Alternative 2, UNP profile frame with bolt combination.
Pros: sturdy construction, able to dampen vibrations, few components needed, easy to disassemble.
Disadvantages: difficult to modify, the manufacturing process requires experts, the process is long, expensive.



Fig. 2. UNP profile frame with bolt combination.

- Alternative 3, Hollow iron profile frame with welded assembly.
Pros: easier working process, able to reduce vibration, sturdy, neater construction.
Disadvantages: difficult to disassemble, use a lot of components, the assembly process requires experts.

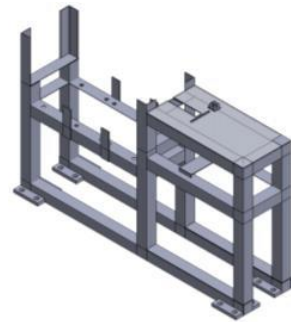

Fig. 3. Hollow iron profile frame with welded assembly.

2. Drive parts

- Alternative 1, Electric motor
Pros: smaller dimensions, relatively cheaper prices, environmentally friendly.
Disadvantages: speed variations are difficult to control, operating costs are more expensive, maintenance is difficult.

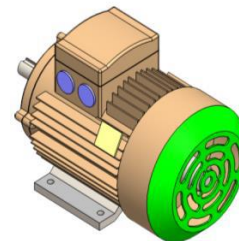

Fig. 4. Electric motor

- Alternative 2, Motor fuel
Pros: does not use electricity so that it can be used in places that do not have electricity, easier starting settings, easier maintenance.
Disadvantages: speed varies but must reduce efficiency, not environmentally friendly, more expensive.

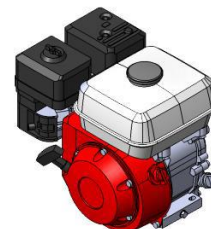

Fig. 5. Motor fuel

- Alternative 3, Diesel motor
Pros: Longer engine life, higher torque, easier maintenance.

Disadvantages: can only use diesel fuel, the price of the engine is much more expensive, the level of air pollution is higher.



Fig. 6. Diesel motor

3. Slicing part

- Alternative 1, Cutting blade holder with bolt and nut fastening system.
Pros: easy to disassemble, easier to maintain, the assembly process does not require experts.
Disadvantages: not strong enough to withstand vibration, not strong enough to withstand impact, more expensive.

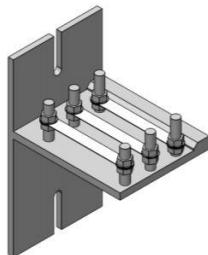

Fig. 7. Cutting blade holder with bolt and nut fastening system.

- Alternative 2, Cutting blade holder with rivet fastening system.
Pros: strong against vibration, simpler and cheaper, easier maintenance.
Disadvantages: difficult to disassemble, not strong enough to withstand impact, not strong enough to withstand large dimensions.

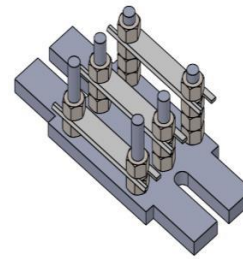

Fig. 8. Cutting blade holder with rivet fastening system.

- Alternative 3, Cutting blade holder with welding fastening system.
Pros: strong to withstand impact, strong to withstand vibration, strong to withstand large dimensions.
Disadvantages: difficult during the disassembly process, the assembly process requires experts, expensive.

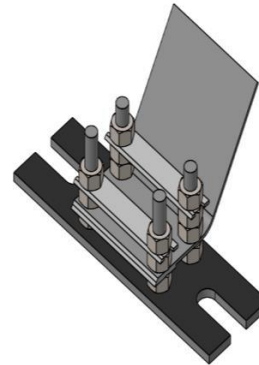

Fig. 9. Cutting blade holder with welding fastening system.

4. Drawstring part

- Alternative 1, Cylindrical cutting blade system is round with 45° cutting angle.
Pros: faster processing, easier processing, sharper cutting edges.
Disadvantages: more shavings left, complicated assembly process.

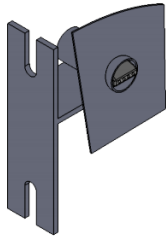

Fig. 10. Cylindrical cutting blade system is round with 45° cutting angle.

- Alternative 2, The cylindrical cutting blade system is rectangular and conical in shape.
Pros: faster shavings, smoother skewers, less shavings left.
Disadvantages: complicated assembly process, twice the shaving process to produce skewers, longer processing time.

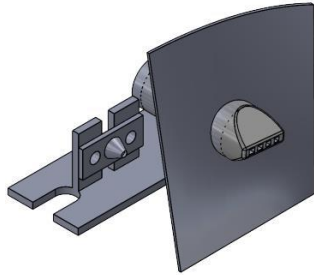

Fig. 11. The cylindrical cutting blade system is rectangular and conical in shape.

- Alternative 3, Conical cutting blade system.
Pros: the skewers are smoother, have different cutting blade profiles, and produce skewers of different sizes.
Disadvantages: the cutting edge is complicated, takes longer, the assembly process is difficult.

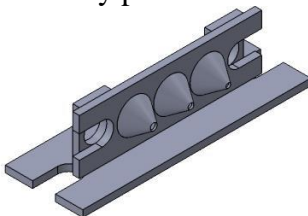

Fig. 12. Conical cutting blade system.

5. Sharpening part

- Alternative 1, Sand the belt sander.
Pros: wider tapering area, longer service life, easy to obtain.

Disadvantages: requires a lot of additional parts, the assembly process is difficult, the price is relatively expensive.



Fig. 13. Sand the belt sander.

- Alternative 2, Sandpaper ring.
Pros: cheaper price, easier assembly process, sanding area on the outside and inside.
Disadvantages: smaller sharpening area, requires additional parts, sandpaper is easy to wear.

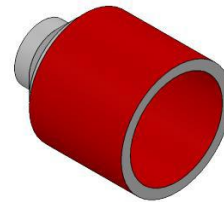

Fig. 14. Sandpaper ring.

- Alternative 3, Round Velcro Sandpaper
Pros: the price is quite cheap, the assembly process is easy, easy to get, the sharpening area is wider.
Disadvantages: sandpaper is easy to wear, the position of the sandpaper must be considered, requires additional parts.

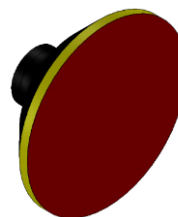

Fig. 15. Round Velcro Sandpaper.

Based on the alternatives of each function part, then they are selected and combined with each other to form a

concept variant of the skewer making machine, with a minimum number of variants of 3 types of concept variants. It is intended that in the selection process there is a comparison and it is hoped that a variant of the concept can be selected that can meet the desired demands. By using a morphological box, the alternatives for each function of the part are combined into an alternative function as a whole as shown in table 1.

Table 1. Morphological Box

| No | Part Function | Alternative Function Part | | |
|----|-----------------|---------------------------|----|----|
| 1 | Frame parts | A1 | A2 | A3 |
| 2 | Drive parts | B1 | B2 | B3 |
| 3 | Slicing part | C1 | C2 | C3 |
| 4 | Drawstring part | D1 | D2 | D3 |
| 5 | Sharpening part | E1 | E2 | E3 |
| | Concept Variant | V1 | V2 | V3 |

Based on the morphology box in table 1, 3 (three) variants of the concept are obtained that are displayed in the 3D model. Each combination of concept variants that are made is then described as an alternative function of the parts used, how it works, and the advantages and disadvantages of combining the concept variants as a skewer making machine. There are 3 (three) variants of the concept of a skewer making machine, which are as follows:

Concept variant 1

In concept variant 1, using a slicing system that can remove 3 (three) bamboo slices with 3 (three) rectangular slicing blades, the slicing blade holder is arranged in layers to thin the bamboo according to the desired size. In the drawstring system, 4 (four) sticks of skewers can be removed with parallel round cutting edges to make round bamboo or skewers. Using a sharpening system in the form of round sandpaper to sharpen the ends of the skewers to make them sharp. The frame construction uses an L profile whose assembly uses welding. The propulsion system uses an electric motor. The design

of the concept variant 1 is shown in Figure 16.

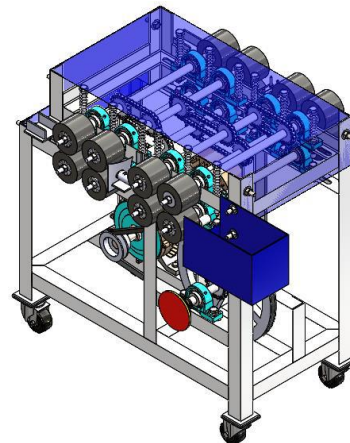

Fig. 16. Design of concept variant 1

Concept variant 2

In concept variant 2, it uses an slicing system that can remove 3 (three) bamboo slices with three (three) rectangular slicing blades, the slicing blade mounts are arranged in layers. In the drawstring system with parallel rectangular cutting edges to make the skewers and next to the cutting blades there is a skewer stick maker that comes out 1 (one) with a round cutting edge to make skewers. Using a sharpening system in the form of roller sandpaper with a wider sharpening area. The frame construction uses materials that are formed by a cast mechanism with a combination of bolts. The propulsion system uses an internal combustion engine and uses a reducer to adjust the speed ratio of the engine. The design of the concept variant 2 is shown in Figure 17.

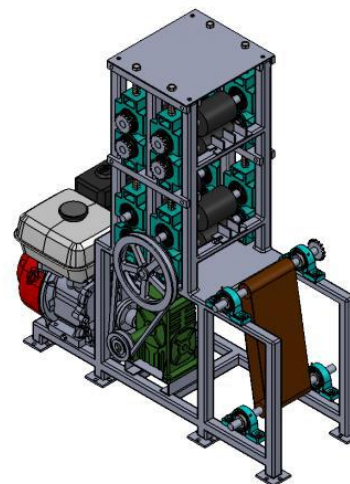

Fig. 17. Design of concept variant 2

Concept Variant 3

In concept variant 3, it uses a cutting system to cut long bamboo into the desired size and the bamboo entry system or bamboo push system uses a piston. The slicing system can remove 3 (three) bamboo strands with 3 (three) rectangular blades, the blade holder is arranged in layers and can be disassembled. In the drawstring system, 3 (three) sticks of skewers can be removed with round cutting edges that are parallel to different round sizes to make bamboo sticks into skewers. Using a sharpening system in the form of cylindrical sandpaper to sharpen the ends of the skewers to make them sharp. The frame construction uses an L profile with a combination of hollow iron with welded assembly. The propulsion system uses an electric motor and uses a reducer to adjust the speed ratio of the engine. The design of the concept variant 3 is shown in Figure 18.

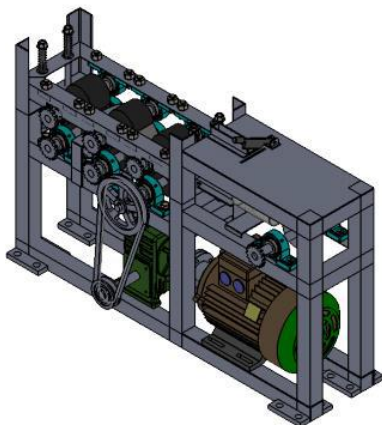

Fig. 18. Design of concept variant 3

After obtaining 3 (three) variants of the design concept of the skewer making machine, the next step is to choose the best one of the three variants. The selection process is carried out by providing an assessment of the three variants. The criteria for the assessment aspect are divided into two groups, namely the assessment of the technical aspect and the economic aspect. For the assessment of technical aspects, the elements assessed are: main function, manufacturing process, standard components, assembly,

maintenance, safety and ergonomics. Meanwhile, to assess the economic aspects of the elements assessed are manufacturing costs and maintenance costs.

Based on the assessment process that has been carried out, the variant of the concept chosen is the variant with the highest value. From the variants of the concept, the existing sub-functions are then optimized so that a good design result is obtained and is in accordance with what is desired. The chosen variant is concept variant 1 with the highest value compared to other concept variants. Then concept variant 1 was followed up and optimized in the process of designing a skewer making machine.

Conclusions

From the results of the design of a bamboo slicing machine to increase the production of skewers, it is concluded that:

The skewer making machine uses an L profile frame with welded assembly, the driving part uses an electric motor, for the slicing part it uses a cutting blade holder with bolt and nut fastening system. While the drawstring part uses a cylindrical cutting blade system is round with 45° cutting angle and the tapering part uses round Velcro sandpaper.

The skewer making machine is designed to be able to make skewers with a diameter between 2.5 mm to 3 mm and a length of 210 mm and can produce 3000 skewers in one hour.

References

- [1] Nufus, N. et al., 2016. Analisis Hasil Belajar “Mengolah Hidangan Sate atau Jenis Makanan yang Dipanggang” pada Kesiapan Membuka Usaha Siswa. *Media Pendidikan, Gizi dan Kuliner* 5(2), 60–70.
- [2] Setiawan, I., 2017. Sate Maranggi: Kuliner Khas Kabupaten Purwakarta. *Patanjala* 9(2), 277–292.
- [3] <https://www.wowshack.com/rendang->

- nasi-goreng-best-foods/ - (diakses 6 april 2022).
- [4] Adiyastiti, B.E.T., et al., 2014. Pengaruh lama pembakaran dan jenis bahan bakar terhadap kualitas sensoris dan kadar benzo(a)piren sate daging kambing. *Buletin Peternakan* 38(3), 189-196.
- [5] Ekawatiningsih, P., et al., 2008. Restoran. Direktorat Jenderal Manajemen Pendidikan Dasar dan Menengah, Direktorat Pembinaan Sekolah Menengah Kejuruan, Departemen Pendidikan Nasional. Jakarta.
- [6] <https://id.wikipedia.org/wiki/Sate>. (diakses 6 april 2022).
- [7] Widnyana, K., 2012. Bambu dengan berbagai manfaatnya. *Bumi Lestari Journal of Environment* 8(1).
- [8] Ibrahim, G. A., et al., 2019. Pembuatan dan pengujian mesin pemotong lidi tusuk sate. *Jurnal Pengabdian pada Masyarakat* 4(4), 421-430.
- [9] Winarno, J. and Rusdiyantoro, 2016. Rancang bangun mesin irat bambu untuk pembuatan jeruji sangkar burung dan tusuk sate. *Jurnal Teknik WAKTU* 14(1).
- [10] Rahardjo, S. and Priama, U., 2008. Rancang bangun mesin penyerut bambu. *Sintek Jurnal* 2(2), 45-61.
- [11] Ibrahim, G. A., et al., 2019. Pembuatan dan pengujian mesin penyerut tusuk sate mekanik. *Sakai Sambayan* 3(1), 27-33.
- [12] Iswanto, dkk., 2020. Rancang bangun mesin pencoak pipa (pipe notcher) multi dimensi. *Jurnal METTEK* 6(2), 111-120.
- [13] Mulyadi, dkk., 2017. Rancang bangun jig penyambung pipa multidimensi, Prosiding Senaspro, Universitas Muhammadiyah Malang, 309-318.
- [14] Bambang Setiawan & Rasma, 2019. Rancang bangun mesin press briket dari bahan serbuk kayu sistem pneumatik menggunakan 5 tabung percetak. *Turbo: Jurnal Program Studi Teknik Mesin* 8(2), 135-142.
- [15] Budiyanto, E., Yuono, L. D., & Rohman, F. (2020). Analisa proses produksi part number D574-50081-201 menggunakan mesin milling CNC di PT DI. *Turbo: Jurnal Program Studi Teknik Mesin*, 9(2).
- [16] Setiawan, A., Dharma, U. S., & Budiyanto, E. (2020). Pengaruh jenis bahan dan jumlah gigi perontok terhadap kinerja mesin thresher sebagai perontok padi. *ARMATUR: Artikel Teknik Mesin & Manufaktur*, 1(1), 25-34.
- [17] Budiyanto, E., Yuono, L. D., & Farindra, A. (2019). Upaya peningkatan kualitas dan kapasitas produksi mesin pengupas kulit kopi kering. *Turbo: Jurnal Program Studi Teknik Mesin*, 8(1).